

# TEMEC KVR 5 M\_ DOOR OPERATORS

## Operating and Maintenance Instructions

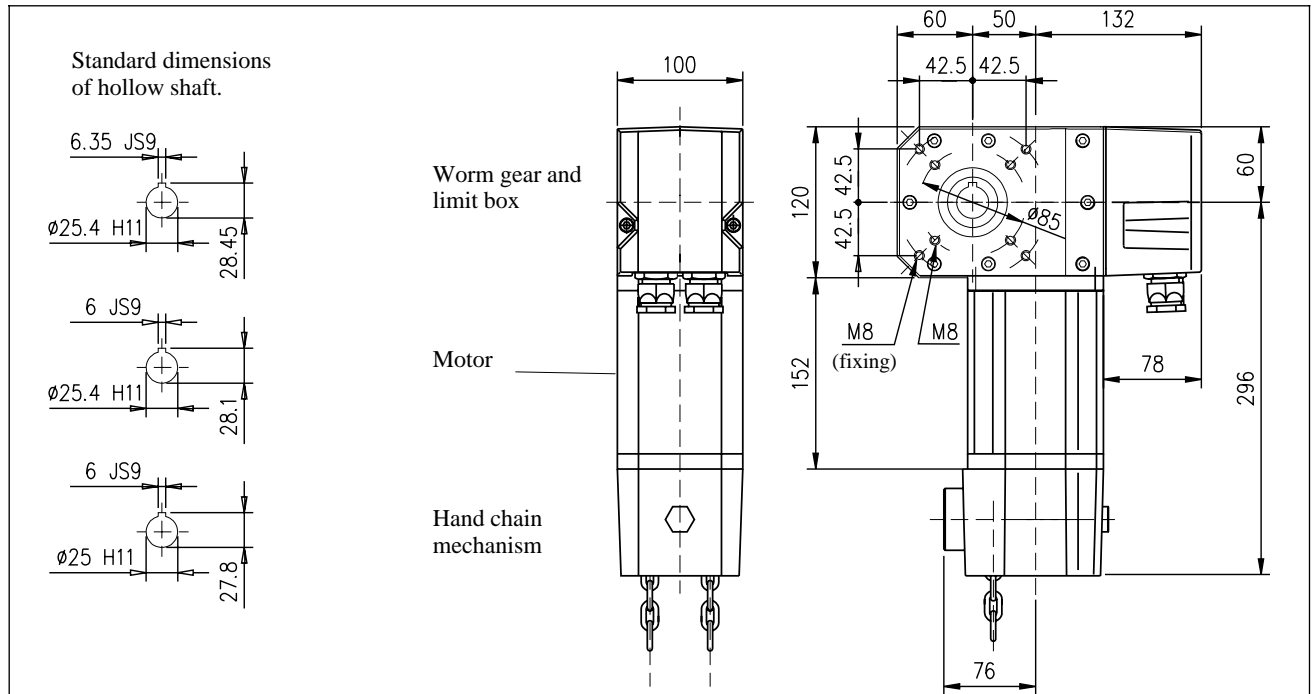

Fig. 1. Hollow shaft operator KVR5 with hand chain device.

## Installation

The drive unit has on both sides of the gear housing fixing holes, from which it can be fastened to a bracket compatible with door frames (not included in the delivery).

If the mounting base is not even, the housing of the gear might be damaged when the fixing bolts are tightened.

When mounting the unit the space required for access to adjust the limit switches should be noted (Fig. 4). The main dimensions of the gear box are shown in Fig. 1.

If the drive is to be transmitted by chain, ensure that the sprockets are in perfect alignment. The fixing of the drive unit must be strong enough to support a maximum chain tension of 5.000 Newtons.

## Electric Connections

An example of the limit switch and electric motor connections is shown in the adjacent picture (Fig. 2). The rated values of the micro switches are 250 V 10 A.

The limit switches can be connected to meet special requirements of different customers. The connections must always be checked so that they conform with the wiring diagram of the corresponding electric control unit.

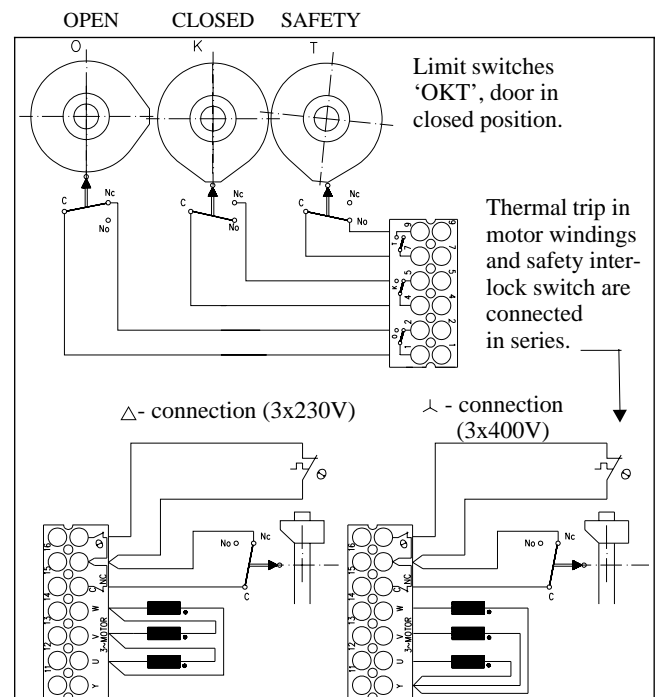

Fig. 2. Example of connections.

## Manual operation

The drive unit can be equipped either with an adapter for the crank handle or with a hand chain mechanism. With this device the motor can be rotated from the floor level.

## Permitted Load

The gear unit has been dimensioned to support a torque of **max. 120 Nm**. It is not allowed to connect the gear unit to drive a mechanism, the operation of which would, e.g. through inertial forces, produce on the output shaft of the gear a torque exceeding the permitted max. torque.

The permitted service life of the gear unit, in operation with the nominal torque of the electric motor, is **12.000** operating hours.

## Adjustment of the Limit Switches

The limit switches will stop the door at each end of the door travel. Additional limit switches can be used for the control of other automatic functions in the door operation, for instance safety devices, traffic lights etc.

**NOTE:** The limit switches must be set before power is applied to the operator.

- Remove the terminal/limitbox cover from the operator. The limit switches are supplied unset.
- The limit switches can be easily identified: 'GREEN' is for 'OPEN' and 'WHITE' is for 'CLOSE'.
- Manually pull the door in the close direction, noting the direction of travel of the white cam, until the desired closed position is reached.
- Loosen the locking screw on the limit cam and rotate the cam in the required direction. For fine adjustment use the adjustment screw. Secure in position by the locking screw.
- Repeat the steps for the open direction of travel.

The activating positions of the cam wheels must be checked with the wiring diagram of the electric control unit. Normally the cam wheel "T" is used to disconnect the reversing function of the safety edge just before the door has reached its fully closed position.

**After initial installation the rotation direction of the electric motor may be wrong.** For this reason it is important to be prepared to press the stop-button, because incorrect rotation may result in damage to the door. To correct the operator direction, interchange two of the incoming supply phases with each other.

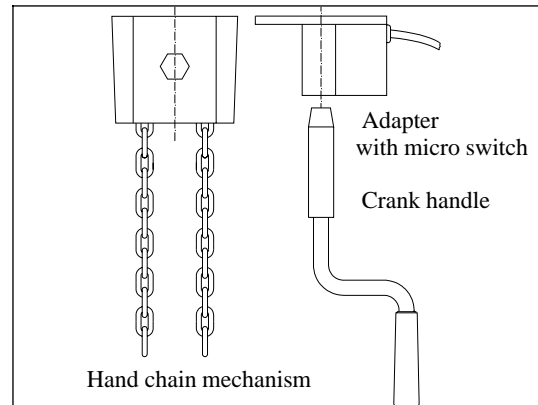

Fig. 3. Manual operation.

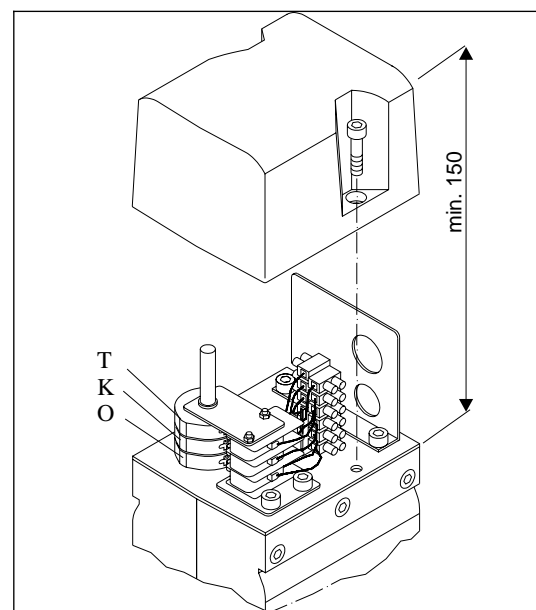

Fig. 4. Limit switches.

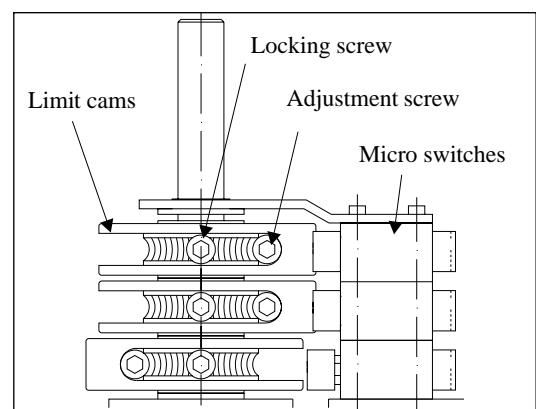

Fig. 5.



## Fault Tracing

Very often faults in electric door operation originate from peripheral devices connected to the control system (e.g. alignment of photo cells). The first thing to do is to find out, whether the fault is located in the door construction itself, or in the electric control systems, or in the drive unit.

In the case of such door types, as when they are in perfect condition also can be opened and closed manually, proceed as follows: Disconnect the drive unit from electric operation and get the door released for manual operation by some means. After this it should be possible to easily move the door manually in both directions over the complete travel of the door. If the door moves, but only very heavily, the fault is in the door construction or in its balancing arrangement. The door must be repaired, or the CAUSES of the bad functioning must be removed.

For tracing electric faults move the door manually into half open position and connect the drive unit to electric operation. Turn the selector switch of the electric control system into push-button operation and press the push-buttons to check, whether the contactors in the electric control unit are functioning.

### The contactors are not pulling in:

Check the position of the current overload relay next to the contactor. In the electric motors there is a thermistor (thermal protector switch) in the stator windings. The function of the thermistor is automatic and it has no manual reset, but the motor must be permitted to cool down. Check the fuses of the control circuit. Check the micro switches of the limit

switches as well as the wirings and switches in the safety circuits for e.g. wicket door, manual door locking, safety edge or any kind of detection or surveillance devices. If all these are in proper condition, the fault must be found in the printed circuit board of the control unit.

### The contactors are functioning:

Measure the phase currents to the motor and check whether the junction box supply voltage is correct. If the voltages are correct, the mains circuit is all right. If one of the phases is missing, one phase winding of the motor has burned out or broken.

For tracing faults in the gear box start the motor and check that the output shaft rotates. If the output shaft does not rotate, teeth of the worm wheel have broken.

The chart below (Fig. 8) presents a simplified fault tracing scheme. It should be noted that installation, maintenance and repair of electrically operated doors are subject to strict safety regulations and should be carried out only by an authorized maintenance company with qualified staff and suitable equipment.

Every complete drive unit has a *rating plate* which shows, in addition to the technical information, also the production serial number (e.g. MLN3059/1), on the basis of which all original production information can be traced later. In all questions related to service, spare part deliveries or claims it is extremely important to refer to the serial number. With reference to this number it will be possible to clear up in detail important matters related to production, quality control and deliveries. Record the serial number of the drive unit e.g. on the first page of this manual.

